



**PLATFORM OSCILLATIONS UNDER THE INFLUENCE OF
INTEGRATED WEAPON'S RECOIL FORCE**

Nina Živanović^{1}, Gordana Bogdanović²*

Received in October 2018

Accepted in December 2018

RESEARCH ARTICLE

ABSTRACT: Oscillations of light wheeled vehicle's centre of gravity, caused by firing weapon integrated on it, are studied through simulation of its axial and angular displacements. Dynamical model of system with three degrees of freedom is used and mathematical model of oscillations is defined using the Lagrange's equations of second order. Weapon recoil force and resistance force that causes vehicle's oscillations is calculated according to the internal ballistics data of integrated weapon and chosen system construction. System of differential equations is numerically solved in MATLAB for real firing conditions and vehicle configuration. Coordinates of weapon mount and elevation and azimuth angles are varied and results are analyzed.

KEY WORDS: oscillations, dynamical model, wheeled vehicle, integrated weapon

© 2019 Published by University of Kragujevac, Faculty of Engineering

¹*Nina Živanović, MSc, Military technical institute, Ratka Resanovića 1, 11000 Belgrade, nina.zivanovic.kg@gmail.com (*Corresponding author)*

²*Gordana Bogdanović, PhD Assoc. prof., University of Kragujevac, Faculty of Engineering, Kragujevac, Sestre Janjić 6, gocab@kg.ac.rs*

OSCILACIJE PLATFORME IZAZVANE SILOM TRAZAJA INTEGRISANOG ORUŽJA

REZIME: Oscilacije težišta lakog vozila točkaša nastale delovanjem oružja integrisanog na vozilo analizirane su simulacijom linijskih i ugaonih pomeranja. Korišćen je dinamički model sistema sa tri stepena slobode koji je matematički modeliran pomoću Langraževih jednačina druge vrste. Sila trzaja oružja i sila otpora koje izazivaju oscilacije vozila određene su na osnovu podataka dobijenih iz unutrašnje balistike integrisanog oružja i izabrane konstrukcije sistema. Sistem diferencijalnih jednačina je numerički rešen u MATLAB-u za realne uslove paljbe i koncepcije vozila. Varirane su vrednosti koordinate tačaka oslanjanja oružja, elevacije i azimuta variraju i analizirani su dobijeni rezultati.

KLJUČNE REČI: oscilacije, dinamički model, vozilo točkaš, integrisano oružje

PLATFORM OSCILLATIONS UNDER THE INFLUENCE OF INTEGRATED WEAPON'S RECOIL FORCE

Nina Živanović, Gordana Bogdanović

1. INTRODUCTION

Systems composed of light mobile platform with integrated weapon rise interest over the past few years because modern warfare require light military vehicles in the arsenal, with few crew members, efficient, not too expensive, intended for scouting, quick actions, neutralization and instant prevention of hostile forces.

Well-equipped armies have purpose-designed tactical vehicles, while less developed countries and paramilitary forces use improvised, already available, adapted vehicles. As a mobile platform, modified light commercial vehicle on wheels is most commonly used (pickup vehicles, utility vehicles). Besides the basic purpose, it also has to absorb additional load from weapon's recoil force. For this paper, Land Rover Defender 110 is selected as a mobile platform and automatic grenade launcher 30 mm caliber M93 as a weapon for integration.

Mathematical-mechanical model of system's oscillations was set based on theoretical approach for studying vehicle dynamics and differential equations of motions were derived. Referring to internal-ballistic data for weapon and vehicle construction parameters, specific equations of platform oscillations are acquired, which can be numerically solved in one of contemporary software packages.

Simulation, which is actually process of solving previously set equation system, is performed in MATLAB environment, giving the graphical representation of results, in this case system oscillations. With initial parameters variations, system precision and alteration of oscillations can be perceived.

2. WEAPON INTEGRATION ON PLATFORM

Weapon can be integrated on several places on the vehicle – it can be mounted on one of the reinforcing bars in the vehicle trunk, between the front seats, above the engine compartment, in front of the passenger seat or in some other place where crew members can operate it from. One of the simplest mounts is vertical bar fastened to vehicle floor. This kind of integration allows specified weapon elevation and azimuth adjustments, while the weapon remains fixed in the same place. More flexible solution is swing arm mechanism composed out of several axles ('arms'), which can cover up to 180° degrees along the horizontal direction. There are also mechanisms as 360-degree turret mounts allowing weapon 360° degrees rotation.

Common practice is to mount weapon in the longitudinal vertical symmetry plane, or as close to it as manageable, so destabilizing moments are the smallest possible. Vehicle has a specific task to carry out when weapon is mounted on it – beside the loads transferred from the road, it has to withstand and absorb weapon generated loads. Main problems for this are inadequate stiffness of the vehicle chassis, adverse oscillations, low weapon firing precision etc. To fulfil these demands and solve occurring problems, the most important thing is to integrate weapon in optimal place and to provide suitable vehicle suspension system which can absorb loads, reduce oscillations and prevent resonance from happening.

2.1 Force transferred to the platform calculation

Automatic grenade launcher 30 mm M93 (Figure 1) was developed from Russian AGS-17 and uses blowback as operating principle.

Main targets of automatic grenade launchers are unsheltered troops or lightly sheltered targets and lightly armored vehicles. Those are convenient for mounting on military vehicles, boats and helicopters [1].



Figure 1. Automatic grenade launcher 30 mm M93

In Table 1 technical data for automatic grenade launcher 30 mm M93 are given.

Table 1. Technical data for AGL 30 mm M93 [2]

Data	AGL 30 mm M93
Empty weapon mass	35 kg
Bullet mass	0,360 kg
Effective firing range	1700 m
Vertical field of action	$(-5^\circ) \div (+70^\circ)$
Horizontal field of action	No tripod movement - 30° , with tripod movement - 360°
Muzzle velocity	185 m/s
Maximum pressure in barrel	$150 \cdot 10^6$ Pa

Within the simulation, internal-ballistic calculation [3] based on Drozdov method had been done and acquired values of maximum pressure in the barrel ($p_{max} = 141,7$ MPa) and projectile muzzle velocity ($v_0 = 186,4$ m/s) were used as initial parameters for further computation. Obtained values barely deviate from the real ones.

Working principle of AGL is simple blowback, which obtains energy, used to perform automatic operation of a weapon, from residual pressure of propellant gasses. Motion of the parts is slowed by the mass of the bolt and the force required to compress the action spring [4]. In automatic grenade launcher 30 mm M93 internal friction force, spring resistance

force and hydraulic resistance force oppose to the motion of the recoil mass. Those forces together compose total force of resistance to recoil R [N], the force that is transferred to the platform and calculated according to the next equation:

$$R = F_{tr} + 2 \cdot F_{op} + F_{hk} - m_t \cdot g \cdot \sin \alpha \quad (1)$$

Figure 2 shows all of the resistance forces which occur during recoil process over time, as well as the total force of resistance to recoil.

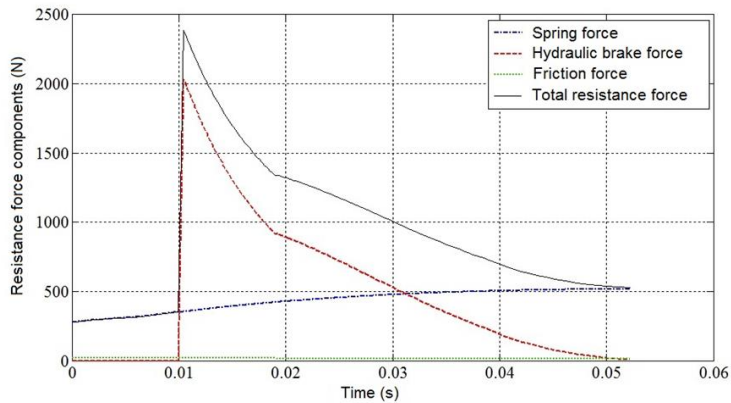

Figure 2. Resistance forces and total force of resistance to recoil

Hydraulic brake absorbs the most of recoil mass' kinetic energy, ca. 80%, so it has the biggest impact on R force change [5]. Maximum value of total force of resistance to recoil is $R_{max} = 2385,9$ N, selected for further calculation.

3. INTEGRATING AGL 30 MM ON SELECTED LIGHT MOBILE WHEELED PLATFORM

Decision was made to mount automatic grenade launcher on the rooftop of the Land Rover Defender in the area above the back seat. Created model had to be simplified, but sufficiently accurate replacement for the real and complex system. Chosen simplified model has three degrees of freedom – translation of mass centrum in the direction of vertical axis z (T_z) and rotations around longitudinal x and lateral y axis (roll R_x and pitch R_y).

From a constructive point of view, simplifications include integration of weapon on the vehicle's longitudinal axis, solid link between them, not deforming construction, assumption that the system behaves as a compact mass, equal spring stiffness coefficients c_{ij} , as well as equal damping coefficients of front and back shock absorbers k_{ij} .

When weapon fires, resistance force to recoil R transfers to elastically suspended platform and causes system to oscillate, which makes it an excitation that takes the system out of

equilibrium position. With cessation of excitation system continues to oscillate, damped using shock absorbers, until it stops in equilibrium position.

In Figure 3 system scheme is shown, observed in xz plane, in right-hand oriented, stationary, perpendicular coordinate system attached to the ground (xyz). Coordinate system $x'y'z'$, attached to the system mass centrum T , moves with the system, a and b are distances from vertical axes of front and back vehicle axles, H_T is height of the mass centrum measured from the ground. Driving force operates in the point D , which position is defined by d and h distances from system mass centrum T in $z'x'$ plane.

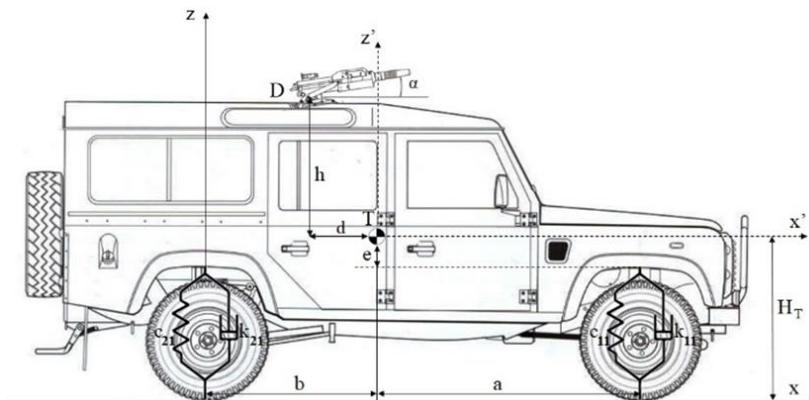

Figure 3. Simplified system scheme in the xz plane

In Figure 4 the same system is shown, observed from the front in the $z'y'$ plane. Labels s are distances from system mass centrum T to left and right wheel vertical axes.

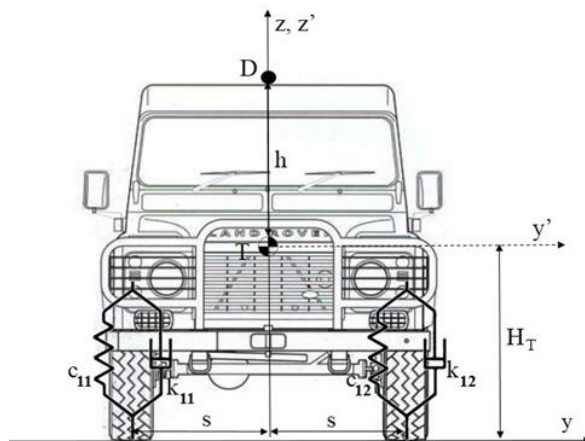

Figure 4. Bi-fuel systems (CNG or biogas) on passenger vehicle Volvo S80

In $z'x'$ plane (Figure 5) side of the system is observed, translation in the z' axis direction, one of the front wheels and one of the back wheels, as well as rotation around y' axis (pitch) for angular displacement φ , in the arbitrary point in time.

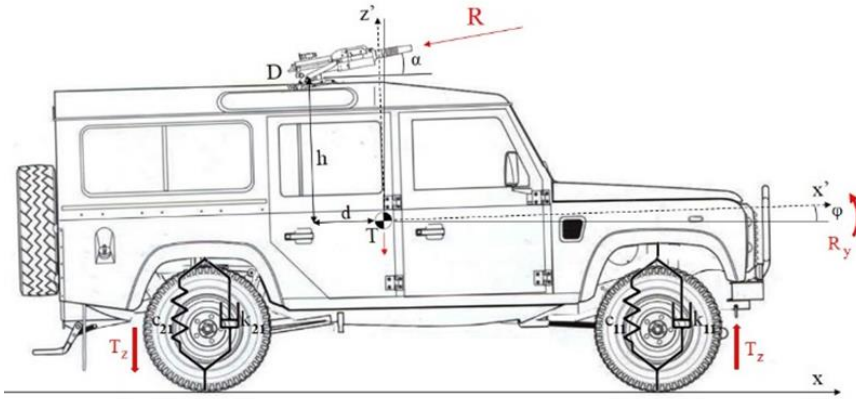

Figure 5. System model in the arbitrary point in time during the driven oscillation in zx plane

In the $z'y'$ plane (Figure 6) system is observed from the front, vertical translation and rotation around x' axis (roll) for angular displacement θ , also in the arbitrary point in time.

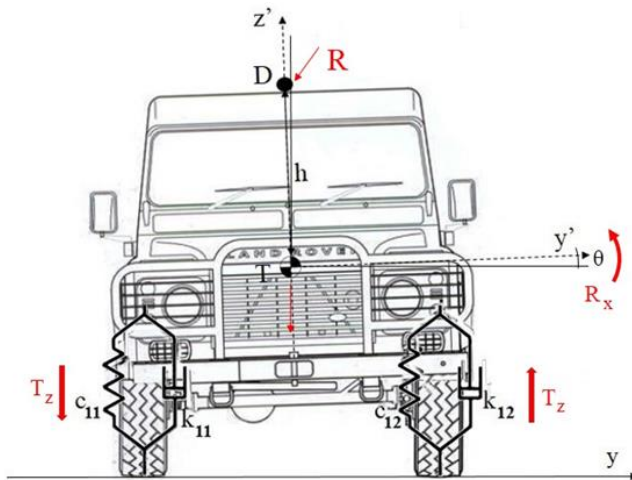

Figure 6. System model in the arbitrary point in time during the driven oscillation in yz plane

For simulation, weapon was fired from top of the stationary vehicle, elevation and azimuth angles defined in advance. For simplified model, differential equations as a description of system's motion were set.

4. MATHEMATICAL-MECHANICAL MODEL OF MOBILE PLATFORM OSCILLATIONS UNDER THE IMPACT OF WEAPON'S RECOIL FORCE

Mathematical-mechanical model represents movement of the physical system based on the classical principles of vehicle dynamics theory and includes all main influencing parameters [6]. Considering adopted simplifications, system with infinite number of degrees of freedom is reduced to system with three of them. Chosen coordinates are: z_T – vertical position of mass centrum T , φ – rotation around lateral axis y' (pitch), θ – rotation around longitudinal axis x' (roll).

Lagrange equations, second-order partial differential equations are used to describe movement of the modeled platform with integrated weapon [7], induced by the force generated when fired out of it:

$$\frac{d}{dt} \left(\frac{\partial E_k}{\partial \dot{q}_i} \right) - \frac{\partial E_k}{\partial q_i} = - \frac{\partial E_p}{\partial q_i} - \frac{\partial \Phi}{\partial \dot{q}_i} + Q'_{q_i} \quad (2)$$

Labeled $i = 1, n$, and n is the number of degrees of freedom for system motion (in this case $n = 3$), E_k – system kinetic energy, E_p – system potential energy, Φ – dissipative function, $\left(- \frac{\partial E_p}{\partial q_i} \right)$ – generalized conservative force (negative partial derivative of potential energy by generalized coordinate i), $\left(- \frac{\partial \Phi}{\partial \dot{q}_i} \right)$ – generalized dissipative force (negative partial derivative of dissipative function by generalized velocity i), Q'_{q_i} – arbitrary non-conservative generalized force.

Total system kinetic energy consists of mass centrum translator kinetic energy and rotational kinetic energy, around the mass centrum:

$$E_k = \frac{1}{2} \cdot m \cdot \dot{z}_T^2 + \frac{1}{2} \cdot J_y \cdot \dot{\varphi}^2 + \frac{1}{2} \cdot J_x \cdot \dot{\theta}^2 \quad (3)$$

J_y is moment of inertia of system mass in regard to longitudinal axis y' , and J_x is moment of inertia of system mass in regard to lateral axis x' .

Formula for potential energy of the system, for equal values of spring stiffness coefficients is:

$$E_p = \frac{1}{2} \cdot c_1 \cdot (\Delta_{11}^2 + \Delta_{12}^2) + \frac{1}{2} \cdot c_2 \cdot (\Delta_{21}^2 + \Delta_{22}^2) \quad (4)$$

Labeled Δ_{ij} is total deformation, or displacement of elastic elements. Dissipative function, with calculated derivatives of relative displacements and for equal values of damping coefficients, is

$$\Phi = \frac{1}{2} \cdot k_1 \cdot (\dot{\Delta}_{11}^2 + \dot{\Delta}_{12}^2) + \frac{1}{2} \cdot k_2 \cdot (\dot{\Delta}_{21}^2 + \dot{\Delta}_{22}^2) \quad (5)$$

Generalized non-conservative forces are derived using virtual displacement of the point D in which actuates external force. For computation maximum value of previously calculated resistance force to recoil R_{max} is used. It has three components in the directions of three axes R_x , R_y и R_z , so the formula for virtual work is:

$$\delta A = (R_x(t) \cdot h + R_z(t) \cdot d) \cdot \delta\varphi + (R_y(t) \cdot h) \cdot \delta\theta + (-R_z(t)) \cdot \delta z_T \quad (6)$$

In order to define Lagrange's equations, derivatives of previous formulas for kinetic energy, potential energy, dissipative energy and virtual displacements are appointed and their components sorted by the generalized coordinates. Formed system of differential equations can be noted in matrix form:

$$[A]\{\ddot{q}\} + [B]\{\dot{q}\} + [C]\{q\} = \{Q\} \quad (7)$$

[A] is matrix of inertia or matrix of masses, [B] is damping matrix, [C] stiffness matrix, and {Q} is driving force vector. When substitution of matrixes takes place matrix (7) becomes matrix (8).

$$\begin{aligned} & \begin{bmatrix} m & 0 & 0 \\ 0 & J_y & 0 \\ 0 & 0 & J_x \end{bmatrix} \begin{Bmatrix} \ddot{z}_T \\ \ddot{\varphi} \\ \ddot{\theta} \end{Bmatrix} \\ & + \begin{bmatrix} 2 \cdot k_1 + 2 \cdot k_2 & 2 \cdot k_1 \cdot a - 2 \cdot k_2 \cdot b & 0 \\ 2 \cdot k_1 \cdot a - 2 \cdot k_2 \cdot b & 2 \cdot k_1 \cdot a^2 + 2 \cdot k_2 \cdot b^2 & 0 \\ 0 & 0 & 2 \cdot k_1 \cdot s^2 + 2 \cdot k_2 \cdot s^2 \end{bmatrix} \begin{Bmatrix} \dot{z}_T \\ \dot{\varphi} \\ \dot{\theta} \end{Bmatrix} \\ & + \begin{bmatrix} 2 \cdot c_1 + 2 \cdot c_2 & 2 \cdot c_1 \cdot a - 2 \cdot c_2 \cdot b & 0 \\ 2 \cdot c_1 \cdot a - 2 \cdot c_2 \cdot b & 2 \cdot c_1 \cdot a^2 + 2 \cdot c_2 \cdot b^2 & 0 \\ 0 & 0 & 2 \cdot c_1 \cdot s^2 + 2 \cdot c_2 \cdot s^2 \end{bmatrix} \begin{Bmatrix} z_T \\ \varphi \\ \theta \end{Bmatrix} \\ & = \begin{Bmatrix} -R_z(t) \\ R_x(t) \cdot h + R_z(t) \cdot d \\ R_y(t) \cdot h \end{Bmatrix} \end{aligned} \quad (8)$$

Final matrix (8) is valid for time span [0; 0,0522 s] while resistance force to recoil impacts the system and while oscillations of the platform with integrated weapon have driven-damped character.

After excitation ceases, the system continues to oscillate damped by the absorbers until it stops in equilibrium position. Matrix that describes free damped oscillating motion of the wheeled platform with integrated weapon and three degrees of freedom:

$$\begin{aligned} & \begin{bmatrix} m & 0 & 0 \\ 0 & J_y & 0 \\ 0 & 0 & J_x \end{bmatrix} \begin{Bmatrix} \ddot{z}_T \\ \ddot{\varphi} \\ \ddot{\theta} \end{Bmatrix} \\ & + \begin{bmatrix} 2 \cdot k_1 + 2 \cdot k_2 & 2 \cdot k_1 \cdot a - 2 \cdot k_2 \cdot b & 0 \\ 2 \cdot k_1 \cdot a - 2 \cdot k_2 \cdot b & 2 \cdot k_1 \cdot a^2 + 2 \cdot k_2 \cdot b^2 & 0 \\ 0 & 0 & 2 \cdot k_1 \cdot s^2 + 2 \cdot k_2 \cdot s^2 \end{bmatrix} \begin{Bmatrix} \dot{z}_T \\ \dot{\varphi} \\ \dot{\theta} \end{Bmatrix} \\ & + \begin{bmatrix} 2 \cdot c_1 + 2 \cdot c_2 & 2 \cdot c_1 \cdot a - 2 \cdot c_2 \cdot b & 0 \\ 2 \cdot c_1 \cdot a - 2 \cdot c_2 \cdot b & 2 \cdot c_1 \cdot a^2 + 2 \cdot c_2 \cdot b^2 & 0 \\ 0 & 0 & 2 \cdot c_1 \cdot s^2 + 2 \cdot c_2 \cdot s^2 \end{bmatrix} \begin{Bmatrix} z_T \\ \varphi \\ \theta \end{Bmatrix} = \begin{Bmatrix} 0 \\ 0 \\ 0 \end{Bmatrix} \end{aligned} \quad (8)$$

Differential equations are solved for the data defined in advance: firing conditions (elevation angle, azimuth angle, pressure force in the barrel and resistance force to recoil) and vehicle/platform construction parameters (stiffness and damping coefficients, mass centrum coordinates and moments of inertia). This way, platform oscillation equations are obtained, and for them, in regard to time, change of the generalized coordinates and velocities of those changes.

5. SIMULATION OF MOBILE PLATFORM OSCILLATIONS AND RESULTS ANALYSIS

Solving of previously defined system of differential equations represents the main part of the simulation and it was conducted numerically in MATLAB environment. There are three initial data sets: vehicle data – technical data, vehicle mass centrum position, vehicle elastic suspension characteristics, moments of inertia; weapon data – weapon mass, integrating position relative to system mass centrum, elevation and azimuth angles; driven force data – calculated values of resistance force R over time.

For integration point, position on the rooftop above back seat was selected. In Table 2 are shown values of these data for basic setup of the system, used for computation. Labels d and h are horizontal and vertical distances of weapon integration position from mass centrum of vehicle-weapon system, respectively.

Table 2. Weapon data and its basic position

AGL 30 mm M93	
Weapon mass with ammunition, m_a [kg]	38
Horizontal distance of the weapon from the mass centrum, d [m]	0,929
Vertical distance of the weapon from the mass centrum, h [m]	1,033
Elevation angle, α [°]	30
Azimuth angle, β [°]	45

Code in MATLAB uses these data to calculate system mass centrum and solve defined matrixes so generalized coordinates over time are determined – translation of mass centrum and angular displacements, as well as their graphical representation. For analysis purposes of recoil process on platform oscillations when firing integrated weapon, elevation and azimuth angles are varied, and so is the weapon position on the vehicle.

Selected angle values for calculations include boundary conditions for firing automatic grenade launcher mounted on vehicle of choice and an angle between them. Elevation angles are $\alpha = [0^\circ, 30^\circ, 60^\circ]$ and azimuth angles are $\beta = [0^\circ, 45^\circ, 90^\circ]$. For different combination of these angles changes of generalized coordinates are acquired. Label $z_T(t)$ represents translation of system mass centrum relative to basic position over time; $\varphi(t)$ is angular displacement of the system around its mass centrum in xz plane over time, relative to basic position, so called pitch and $\theta(t)$ is angular displacement of the system around its mass centrum in yz plane over time, relative to basic position, so called roll. Initial values of the generalized coordinates are $z_T(0) = 0$ m; $\varphi(0) = 0^\circ$; $\theta(0) = 0^\circ$.

Vital parameters are segregated out of the results and shown in Table 3 for better review and comparison. Segregated parameters are generalized coordinates amplitudes, time needed to reach amplitude (t_A) and time required for system to stops in equilibrium position (t_S).

Table 3. Computation results of system oscillations for different elevation and azimuth angles

α	β	Coordinates	Amplitude	t_A [s]	t_S [s]
0°	0°	z_T [mm]	-0,08	0,36	1,5
		φ [mrad]	5,86	0,31	1,26
		θ [mrad]	0	0	0
	45°	z_T [mm]	-0,056	0,36	1,4
		φ [mrad]	4,14	0,31	1,35
		θ [mrad]	14,61	0,31	1,35
	90°	z_T [mm]	0	0	0
		φ [mrad]	0	0	0
		θ [mrad]	20,66	0,31	1,35
30°	0°	z_T [mm]	-6	0,35	1,82
		φ [mrad]	5,11	0,31	1,35
		θ [mrad]	0	0	0
	45°	z_T [mm]	-4,26	0,35	1,72
		φ [mrad]	3,61	0,32	1,28
		θ [mrad]	12,65	0,32	1,28
	90°	z_T [mm]	0	0	0
		φ [mrad]	0	0	0
		θ [mrad]	17,89	0,32	1,25
60°	0°	z_T [mm]	-10,37	0,35	1,95
		φ [mrad]	2,99	0,31	1,25
		θ [mrad]	0	0	0
	45°	z_T [mm]	-7,33	0,36	1,65
		φ [mrad]	2,12	0,31	1,25
		θ [mrad]	7,31	0,31	1,25
	90°	z_T [mm]	0	0	0
		φ [mrad]	0	0	0
		θ [mrad]	10,33	0,31	1,25

With an increase of the azimuth angle, for constant elevation angle, angular displacement θ (roll) is increasing, while angular displacement φ (pitch) and mass centrum translation z_T are decreasing. Approximately the same amount of time is required for generalized coordinates to reach their amplitude. Time required for system to stop in equilibrium position is longest for the translator displacement z_T .

Value of the vertical translation z_T and angular displacement in xz plane φ notably impacts weapon precision, that is, it can cause shot deviation on target. Data in Table 3 show that amplitudes of those displacements are significant. Rate of fire is tightly dependent on time needed for system to stop in equilibrium position, because every deviation from basic firing position will not give satisfying results. Now it can be concluded that for this type of integration AGL onto the vehicle, it is better to use lower rate of fire or single fire. Angular displacement in yz plane θ creates rotated shooting plane, but does not affect precision. It should be noted that these values are larger than the real ones, because maximum value of the force transferred to the platform was used.

Besides the varying of the elevation and azimuth angles, position of the weapon on the vehicle is also altered (Table 4). For further computation, medium values of these angles were selected ($\alpha = 30^\circ$ and $\beta = 45^\circ$). For horizontal (d) and vertical (h) distance of the weapon integration point from the point T chosen values are $d = [0,929 \text{ m}; 2,787 \text{ m}; -1,393 \text{ m}]$ and $h = [1,033 \text{ m}; 0,619 \text{ m}; 0,103 \text{ m}]$. While varying horizontal distance, vertical distance keeps main value, and vice versa (given in Table 2). Figure 7 is graphical representation of system oscillations for different sets of weapon position coordinates on the platform.

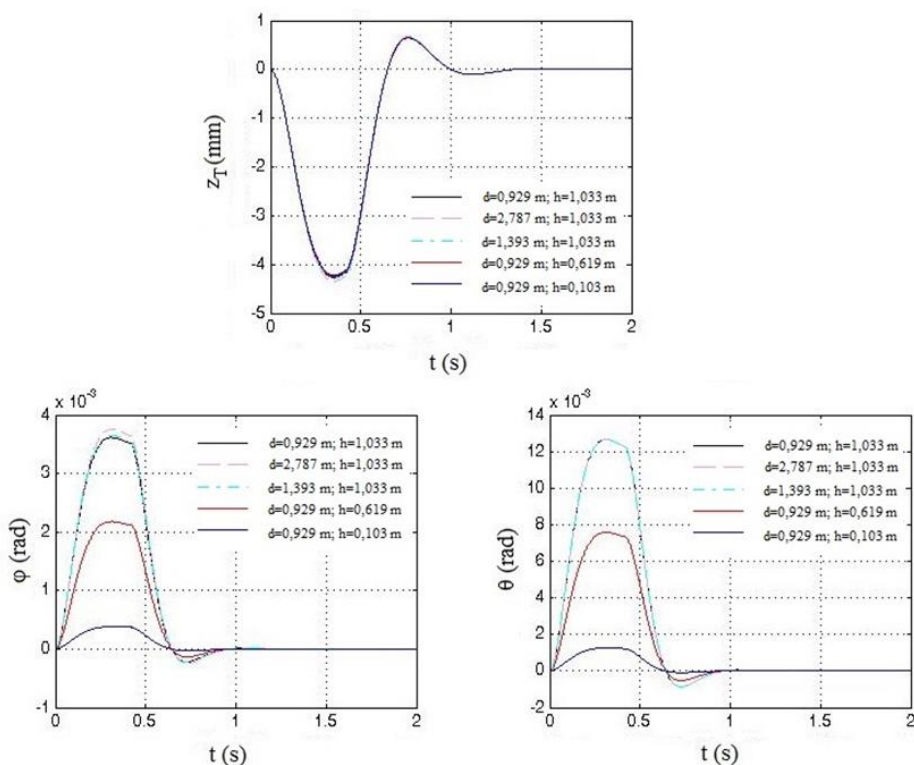

Figure 7. Change of generalized coordinates z_T , φ , θ over time for several weapon positions

These results are displayed in Table 4 in numerical form.

Table 4. Computation results of system oscillations for different position of the weapon on the platform

Distance	Coordinates	Amplitude	t_A [s]	t_S [s]
$d = 2,787$ m	z_T [mm]	-4,34	0,35	1,62
	φ [mrad]	3,75	0,31	1,3
	θ [mrad]	12,65	0,32	1,28
$d = -1,393$ m	z_T [mm]	-4,18	0,35	1,62
	φ [mrad]	3,45	0,29	1,12
	θ [mrad]	12,65	0,32	1,21
$h = 0,619$ m ($H_T = 1010,9$ m)	z_T [mm]	-4,24	0,35	1,71
	φ [mrad]	2,18	0,31	1,09
	θ [mrad]	7,58	0,31	1,21
$h = 0,103$ m ($H_T = 1001,8$ m)	z_T [mm]	-4,22	0,35	1,85
	φ [mrad]	0,38	0,32	1,11
	θ [mrad]	1,26	0,32	1,21

Moving the weapon integration position toward the back or the front part of the vehicle, amplitudes of the chosen parameters practically do not change. Alterations made to weapon position in vertical direction have more influence on generalized coordinates than changes in horizontal direction. When the integration point is closer to the mass centrum, amplitude of the angular displacement θ significantly decreases, amplitude of the angular displacement φ decreases, as well as the time required for the system to stop in equilibrium position (for angular displacements).

6. CONCLUSIONS

Studied in this paper is simplified platform-armament model in order to analyze impact of firing process on light mobile wheeled platform oscillations. Automatic grenade launcher 30 mm M93 is mounted on the Land Rover Defender's rooftop and the goal is that suspension handle additional loads generated when firing weapon, absorbs them adequately so precision on target is maintained. Low precision occurs as a consequence of unsuitable system oscillation evoked by force that transfers to the platform. This paper only pertains recoil process during one fired shot and its impact on system oscillations.

Defined simplified model has three degrees of freedom, mass centrum translation in vertical z axis direction and rotations around longitudinal x axis and lateral y axis. Vertical, longitudinal and lateral system dynamics is studied in two planes, which includes motions vital for oscillation analysis. As a result, generalized coordinates over time are created.

Vertical translation z_T changes as much as 10 mm for high elevation angles. Angular displacement φ has the greatest impact on precision and goes over 5 mrad for zero elevation and azimuth angles, which causes projectile to miss target by 5 meters on 1000 meters distance. Angular displacement θ has the biggest value for zero elevation and maximum azimuth angle, but only rotates shooting plane, precision is not effected. Alterations made to weapon position in vertical direction have more influence on generalized coordinates than changes in horizontal direction. For weapon position close to the mass centrum vertical translation z_T practically does not change, but angular displacements decrease, θ far more than φ . For a precise hit, at 1000 meters distances, displacement of $\varphi = 2 \div 3$ mrad is too much. As mentioned in paper, it should be taken into account that those are oversized values, obtained when maximum recoil force was used. More extensive varying of weapon position

on the platform would enable defining optimal integration point in order to achieve higher rates of fire, preferably maximal rate.

Outcome accuracy depends on quality of the real system simplification. If experimental results are available comparison with the theoretical model can be conducted and simplified model assessed. At last, practical tests can give insight how theoretical model could be updated and, in that way, made more realistic.

First step toward more realistic model is to use variable force transferred to the platform over time, not only its maximum value, and to include process of the recoil mass restoring to starting position in the computation, as well. Extension of the paper can be creating more complex mathematical model with more degrees of freedom and separated masses of integrated components. Elastic suspension system could have more complex geometry or some existing configuration could be acquired. Also, stiffness and damping coefficients could be altered and their impact on the system oscillations monitored. With some adjustments, upgraded model could be used for other weapons and platforms.

REFERENCES

- [1] Jaramaz. S., Micković D. Primena principa komore visokog/niskog pritiska na optimizaciju pogona municije za automatski bacač granata, Mašinski fakultet, Beograd, 2001.
- [2] Uputstvo za korišćenje i održavanje – 30 mm bacač granata automatski, Zastava oružje.
- [3] Cvetković M. Unutrašnja balistika, Vojnoizdavački zavod, Beograd, 1998.
- [4] Petrović M. Mehanika automatskog oružja, Vojnoizdavački zavod, Beograd, 2009.
- [5] Petrović M. Mehanika automatskog oružja, Vojnoizdavački zavod, Beograd, 2009.
- [6] Simić D. Motorna vozila, treće izdanje, IRO „Naučna knjiga“, Beograd, 1988.
- [7] Rašković D. Teorija oscilacija, treće izdanje, Građevinska knjiga, Beograd 1974.